

Symbols

SCRAP

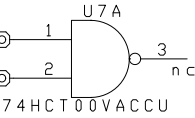

RESET

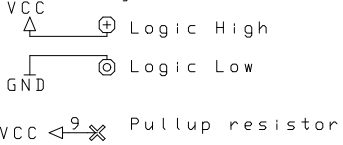
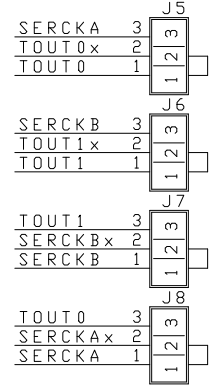
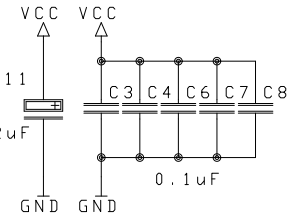
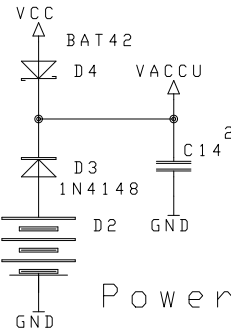
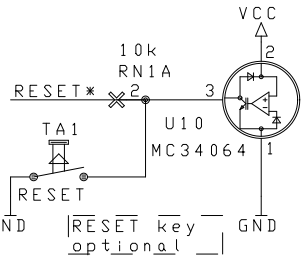

Power

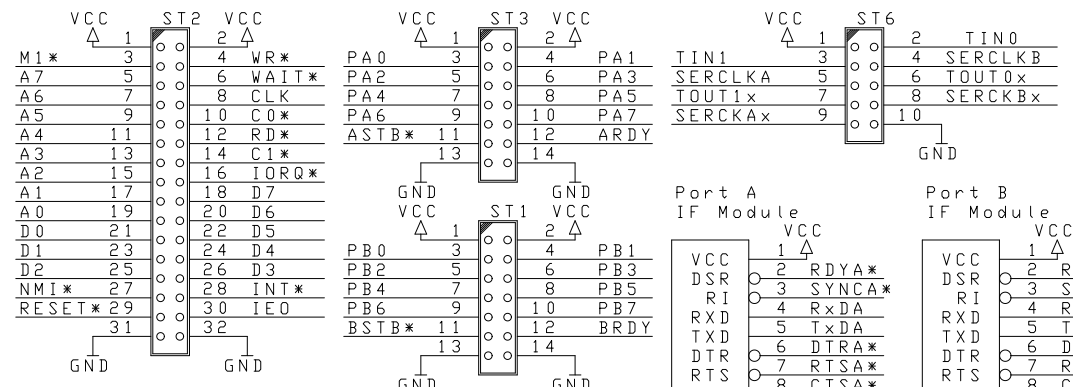
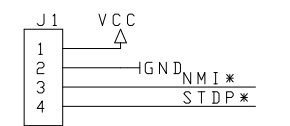

CONNECTORS

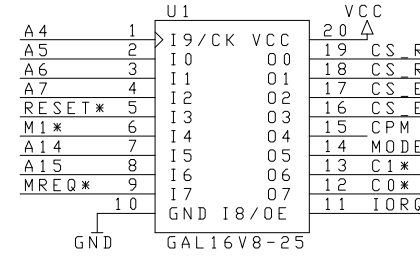
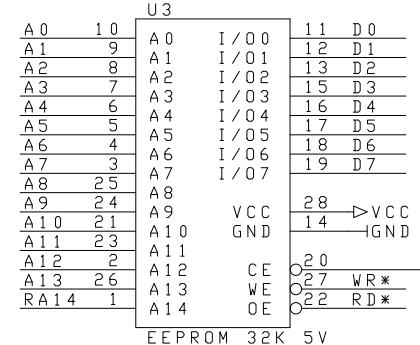
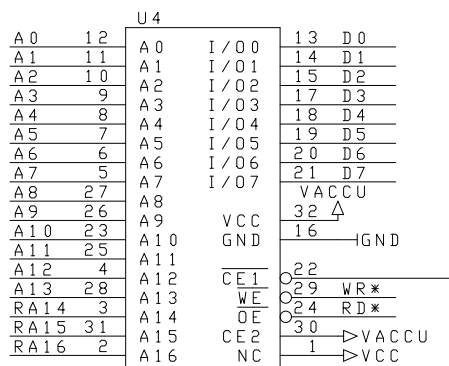
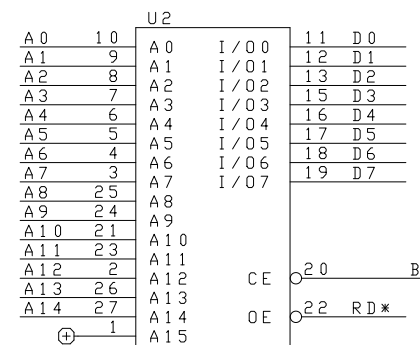

J3	J4	Function
--	--	No EEPROM
--	PAB0	Soft Configuration
Yes	--	EEPROM always active
Yes	Yes	Illegal

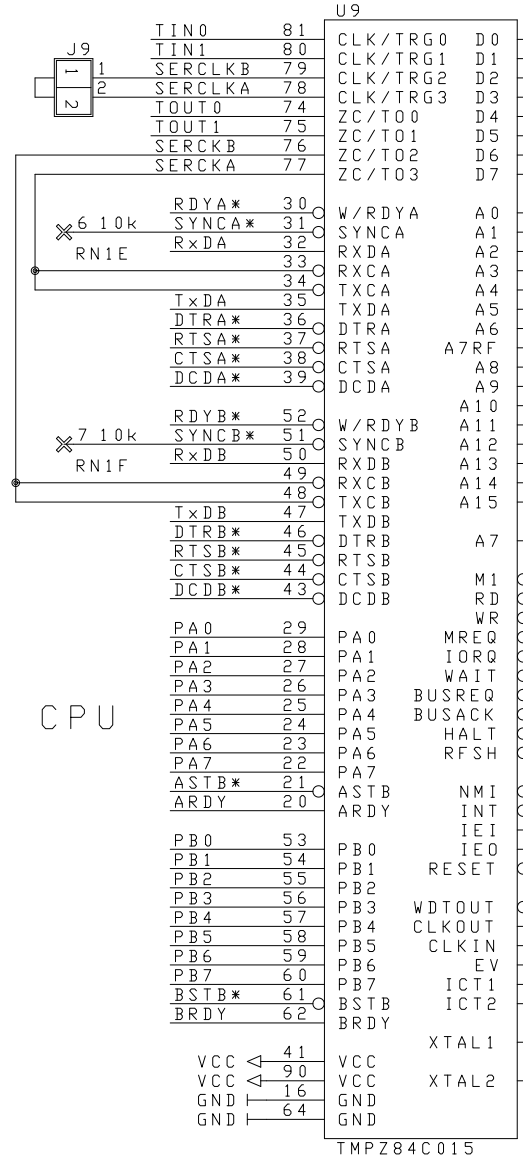
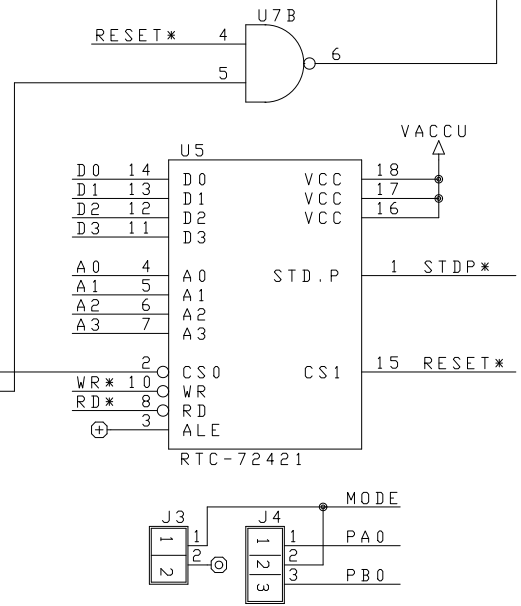

CPU

Clocker GAL

- Divides by 2 to 4
- Latches bank address

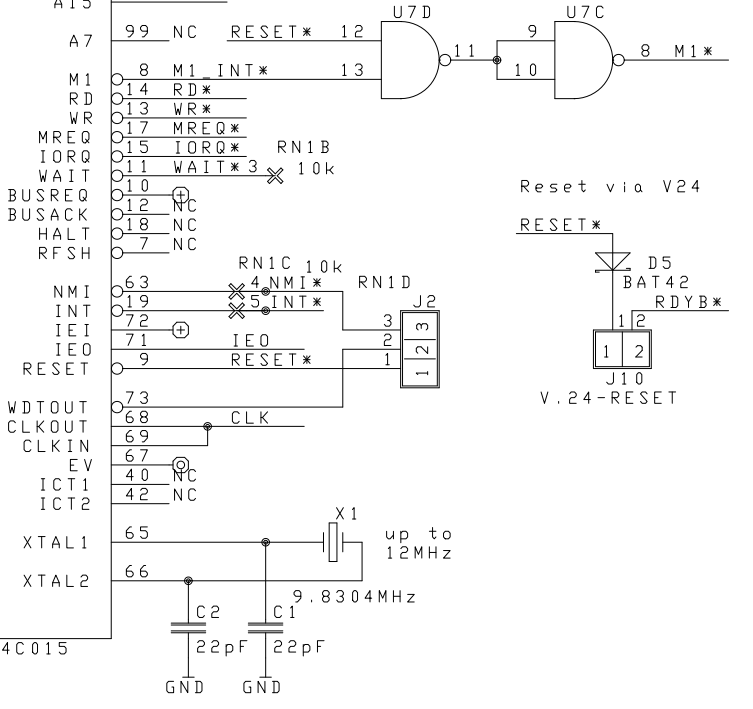
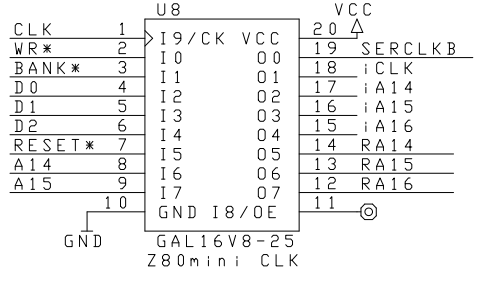

Improvements of 3.00 over 1.00

- Up to 128KB RAM (32KB) in 8 banks
- 2 times faster clock of 9.8304MHz (4.915MHz)
- Separate power connector for easy use of PC power supply or MCT's POWER1
- Hard to use power-fail NMI misfeature replaced
- Better noise immunity through multi layer pcb
- Serial Clock Bug removed
- Power-down-sleep support

Modifications:

- IEO on ST2 works now
- Solder pad to disconnect SERCLKs
- Solder pads to reverse tout pins
- EEPROM has now RA14 from bankswitcher
- U1 is modified for CPM mode
- Reset via V24 feature

MCT Paul & Scherer Mikrocomputertechnik GmbH

Title: Z80mini EMUF - Version 3.10

Size: C Document Number: REV:

Date: September 7, 1993 Sheet 1 of